

Melt pressure Transmitter

GREENLINE Type "GMD-DAI"

0(2)-10V / 0(4)-20mA

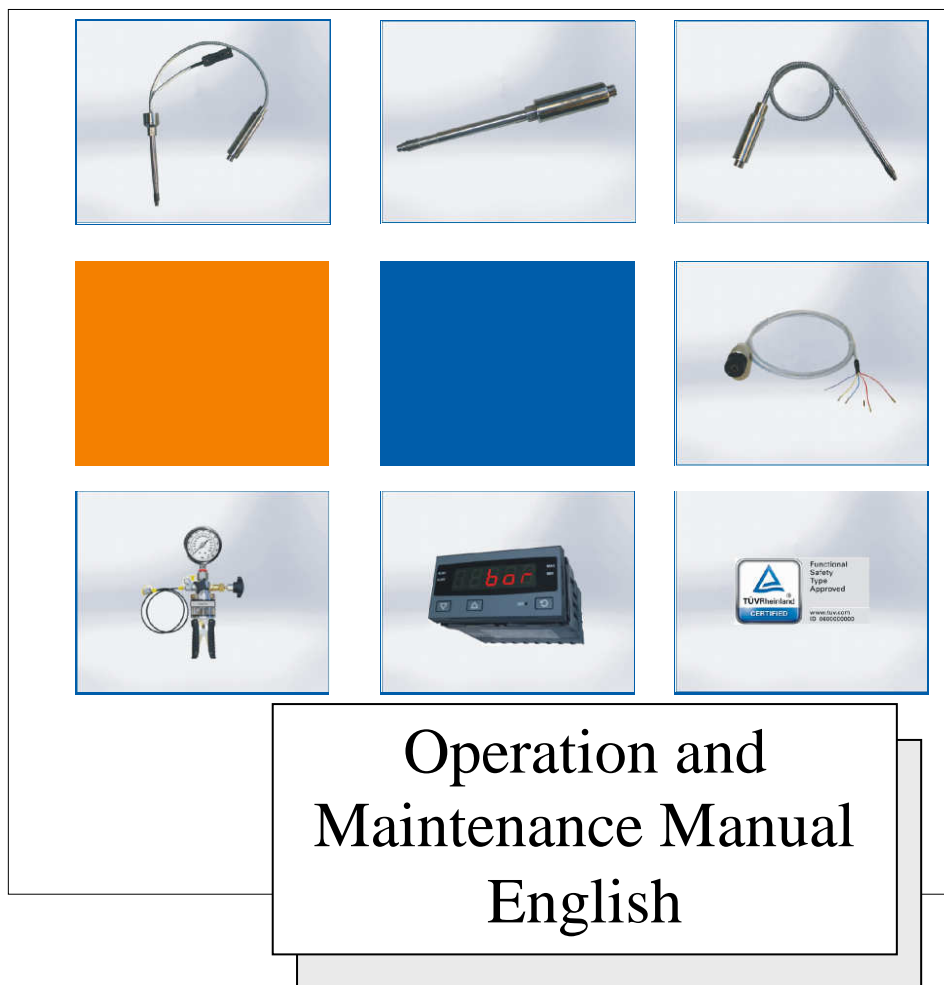

MERCURY FREE
NaK FREE



Contents:

1. Introduction
2. Operating range and field of application
3. Danger areas
4. Waste disposal
5. Transport and storage
6. General
7. Cleaning of the sensors
8. Installing / Uninstalling
9. Connecting and commissioning
10. Technical Data
11. Dimensions

1. Introduction:

Melt pressure transducers are precise measuring probes which obtain their measuring accuracy and long life span only if they are properly handled. These operating instructions should be studied carefully before installing the sensor, thus ensuring a trouble-free operation. Nevertheless, should you encounter any difficulties, please feel free to contact our service technicians, who will be pleased to be of assistance.

2. Operating range and field of application:

Gräff melt pressure transducers have exclusively been designed for the pressure monitoring of liquid, doughy or pasty materials at high temperatures. These must have a homogeneous constitution. The application area has to be selected in such a manner, that a max. differential pressure of 2 % of the measuring range – based on the diaphragm surface - is not exceeded. Any use beyond the above mentioned application area does not conform to regulations.

3. Danger areas:

In the complete application area of the melt pressure transducer, there is a risk of combustion. If the pressure transducer is not installed or uninstalled correctly during the applying of pressure there is a risk of hot media emerging.

4. Waste disposal:

Pressure transducers filled with mercury, have to be disposed of as hazardous waste. A free of charge and ecologically-friendly disposal can be carried out by Gräff GmbH.

5. Transport and storage:

Gräff pressure transducers are generally dispatched in separate packages. In case of mechanical exposure, the sensing diaphragm is protected by an aluminium cap. This cap should be screwed on at all times of storage.

Last update: MAY 2015

This manual is subject to change without notice!

6 General

Please read this manual carefully and completely before installing the sensor! Any damage caused by non-compliance with the operation and maintenance manual voids all warranty claims. We admit no liability for consequential damage.

Warranty:

For the sensor we grant a warranty of 24 months from the date of purchase.

The warranty includes free rectification of defects verifiably caused by the use of faulty materials or poor workmanship. The defective device shall be returned to the manufacturer immediately after the defect has become known together with original sales receipt and fault description.

The right to further claims shall be reserved.

The liability for defects does not cover natural wear and tear and transport damages as well as damages due to non-compliance with the installation instructions, local installation regulations or improper installation.

The manufacturer shall not be liable for any damages not arising on the delivered item itself, especially not for indirect damages, consequential damages or property damages.

We shall reserve the right to repair, rectify or replace the defective goods or refund the purchase price.

Unauthorised removal of our marking (serial number) negates the warranty.

This product is manufactured by:

Gräff GmbH
Temperature Measurement and Control Technology
Bonner Strasse 54
D-53842 Troisdorf

7. Cleaning of the sensors

In order to clean the diaphragm, the sealing surface and the process thread, the sensor must have the same temperature as the plastic melting point. The diaphragm and the sealing surface can be wiped down with a soft cloth, the thread can be cleaned with a steel brush.

(Do not come into contact with the diaphragm surface)

8. Installing / Uninstalling

Installing

On installation of the pressure transducer it is imperative to note, that the sensor bore corresponds to the dimensions mentioned below. The fitting accuracy can be checked by means of a test bolt

Prior to mounting the sensor, the thread should be covered with a heat resistant paste. Should the machinery with the sensor drilling still be at production temperature, a certain preheating period for the sensor should be taken into consideration, in order to avoid a seizing of the sensor due to thermal expansion.

On mounting the transducer, it is important to note that the sensor is not screwed in at an angle and that the sensor does not fall into the bore.

Starting torque for 1/2-20 UNF = max. 30 Nm

Starting torque for M 18 x 1,5 = max. 50 Nm

Uninstalling

The uninstalling of the pressure transducer has to be done in a heated up condition (plastic melting point)

On removal of the sensor, please take note that the diaphragm is not brought into contact.

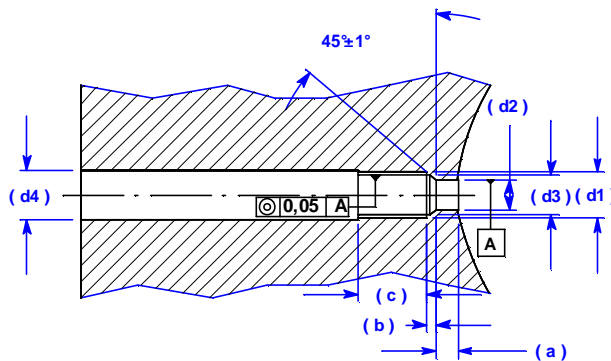

d1	M18x1,5	1/2"20UNF 2A
d2	Ø 10,1 ^{+0,05}	Ø 7,9 ^{+0,05}
d3	Ø 16,1 ^{+0,1}	Ø 10,7 ^{+0,1}
d4	Ø 20 ^{+0,2}	Ø 13 ^{+0,2}
a	6,1 ^{-0,1}	5,7 ^{-0,1}
b	4 ^{-0,2}	3,2 ^{-0,2}
c	25	19

9. Connections and commissioning

After the pressure transducer has been mounted into the line as is described in section 7, the electrical connection then has to be carried out according to the connections indicated on the next page. Gräff pressure transducers are equipped with high-quality and robust plug connections. The connecting wire should be soldered with great care since otherwise, transmission errors of signals can be caused. We recommend to use Gräff prefabricated connecting wires which are available from stock.

For commissioning, the sensor and the corresponding evaluation unit (e.g. Gräff pressure measurement amplifier) have to be calibrated accordingly. **The calibrating process has to be carried out when the line is heated up and at zero pressure.** Please take the details concerning the way how to proceed from the respective operating instructions for the evaluation unit.

Electrical wiring

The integrated amplifier will thereafter transmit the starting value of its output scale (0V at 0...10V, 0mA at 0...20mA and 4mA at 4...20mA output signal). Function is suppressed, if the output signal is more than 5 % of the maximum value.

Afterwards an 80% inspection of the output signal can be performed. All corresponding lead wires need to be connected for this procedure (see wiring diagram). The pressure sensor will now supply a signal which is according to 80% of the measuring value.

Electrical wiring configuration **2-Wire sensor**

Connector type: **PT02A-10-6P**.

4...20mA

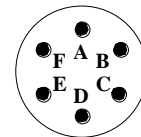
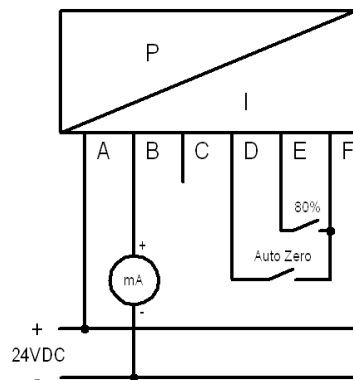

Pin	Function	Colour coding (Gräff – standard)
A	Supply / Signal +	YELLOW
B	Supply / Signal -	GREY
C	free	WHITE
D	Auto Zero	GREEN
E	80%	BROWN
F	Auto Zero / 80%	PINK

Pin D and Pin F are utilised for the activation of the Auto-Zero function. The Zero-point is hereby merely shifted. The signal amplification is not affected, as it is shifted linear to the zero point. In order to generate the 80 % signal, pins E and F must be connected.

Electrical wiring configuration **3-Wire Sensor**

Connector type **PT02A-10-6P**.

0...10V
0/4...20mA

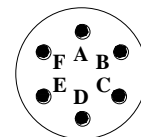
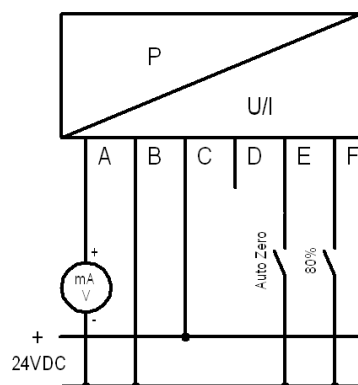

Pin	Function	Colour coding (Gräff – standard)
A	Signal +	YELLOW
B	Supply /Signal/Auto Zero -	GREY
C	Supply +	WHITE
D	free	GREEN
E	Auto Zero	BROWN
F	80%	PINK

In order for the Auto-Zero function to be activated, pins E and B have to be connected with each other. Only the Zero-point is shifted. The signal amplification remains untouched, as it shifts linear to the zero-point. In order to generate the 80 % signal, pins F and B must be connected.

Electrical wiring configuration **4-Wire Sensor**

Connector type **PT02A-10-6P**.

0...10V
0/4...20mA

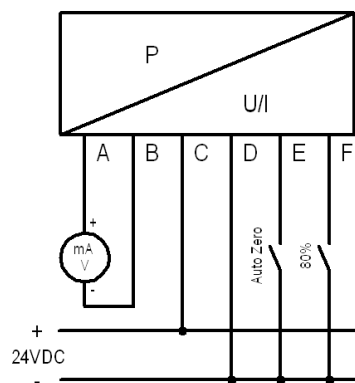
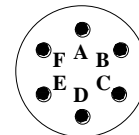

Pin	Function	Colour coding (Gräff – standard)
A	Signal +	YELLOW
B	Signal/Auto Zero - *	GREY
C	Supply +	WHITE
D	Supply / Auto Zero - *	GREEN
E	Auto Zero	BROWN
F	80%	PINK

* Pins B and D are connected internally

In order to activate the Auto-Zero function, pins A, C and D must be connected. Only the Zero point is shifted. The signal amplification remains in place, as it shifts linear to the zero point. In order to generate the 80% signal, pins F, C and D must be connected.

Electrical wiring configuration **2-Wire sensor Version 98**

Connector type: **PT02A-98-P**.

4...20mA

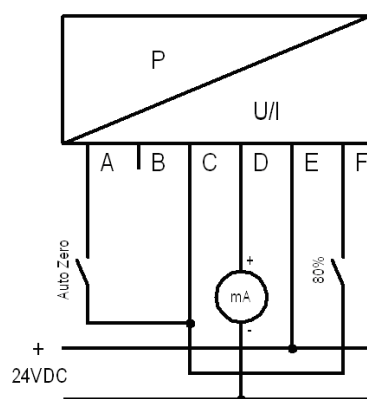
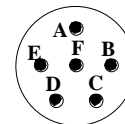

Pin	Function	Colour coding (Gräff – standard)
A	Auto Zero	YELLOW
B	free	GREY
C	80% / Auto Zero - *	WHITE
D	Supply - *	GREEN
E	Supply+	BROWN
F	80%	PINK

* Pin C und D are connected internally

In order to activate the Auto-Zero function, pin A and pin C must be connected. Only the Zero point is shifted. The signal amplification remains in place, as it shifts linear to the zero point. In order to generate the 80% signal, pins F and C must be connected.

Electrical wiring configuration **4-Wire Sensor Version 98**

Connector type **PT02A-98-P**

0...10V
0/4...20mA

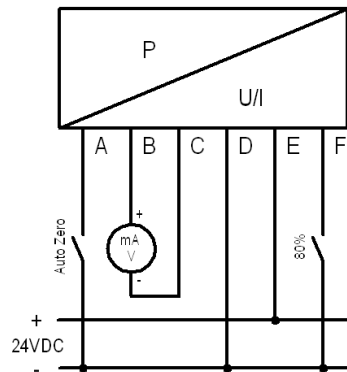
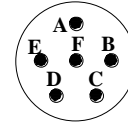

Pin	Function	Colour coding (Gräff – standard)
A	Auto Zero	YELLOW
B	Signal +	GREY
C	Signal/Auto Zero - *	WHITE
D	Supply/Auto Zero - *	GREEN
E	Supply +	BROWN
F	80%	PINK

* Pins C and D are connected internally

In order to activate the Auto-Zero function, pins A, C and D have to be connected. This leads to a shifting of the zero point. The signal amplification remains in place, as it shifts linear to the zero point.

The 80 % signal is generated by connecting pins F,C and D

Electrical wiring configuration **2-Wire sensor**

Connector type: **P8** (PC06A-12-8P)

4...20mA

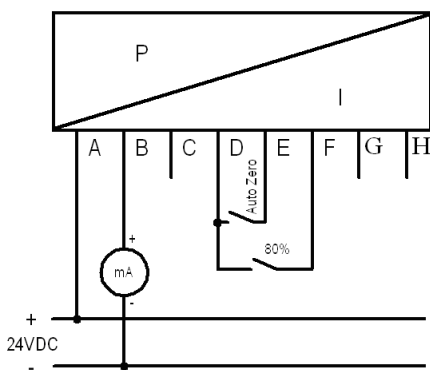
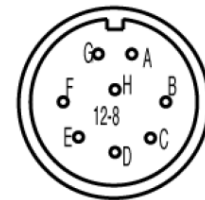

Pin	Function	Colour coding (Gräff – standard)
A	Supply / Signal +	YELLOW
B	Supply / Signal -	GREY
C	free	WHITE
D	Auto Zero / 80%	GREEN
E	Auto Zero	BROWN
F	80%	PINK
G	free	---
H	free	---

Pin D and Pin E are utilised for the activation of the Auto-Zero function. The Zero-point is hereby merely shifted. The signal amplification is not affected, as it is shifted linear to the zero point.

In order to generate the 80 % signal, pins D and F must be connected.

9. Technical Data:

Pressure range:	See order specification
Supply:	19...32 VDC
Output signal:	0...10 V; 0...20 mA; 4...20 mA (see order specification)
Calibration point:	80 % of measuring range
Accuracy:	< +/- 0,50 % FSO
Maximum over load:	150% of measuring range
Zero deviation with temperature Variations at the membrane::	< +/- 0,003 % from final value/°C
Zero deviation with temperature Variations at the measuring head:	< +/- 0,003 % from final value/°C
Maximum temperature at the membrane:	400 °C
Maximum. Temperature at the measuring head:	85 °C
EMC: according to	Electromagnetic disturbances and electromagnetic susceptibility EN 61326
Degree of protection:	IP 55

11. Dimensions

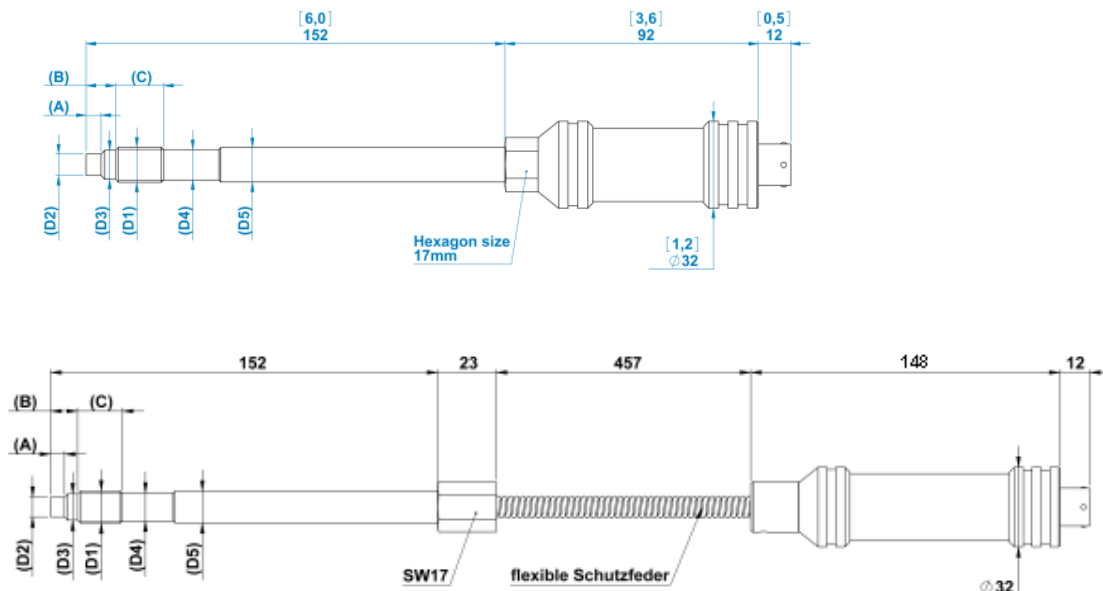

For available variations see order specification

Please observe the following warnings!

- Torsion of the connection cables shall be avoided.
- The capillary must not be exposed to mechanical tensile loading.
- The temperature range of the extension / probe tip / capillary must be observed.
- If the device is not moisture-proof, the line / measuring sleeve must not be exposed to moisture.
- For all standard types vibrations and oscillations shall be avoided. This does not apply to products specifically intended for this purpose (see quality characteristics).
- Use only suitable tools for installation.
- Any modification of the sensor structure and the use for other purposes are prohibited.
- Mechanical loading can destroy the temperature sensor.

If a risk-free operation can no longer be assumed for men and machine, the sensor shall be put out of operation and assured against unintended operation.

It can be assumed that a risk-free operation is no longer possible if:

- the sensor or the connection cable show visible damages,
- the sensor does no longer operate in accordance with its specifications,
- after the sensor has been exposed to severe stresses during transport.